



Available online at <http://scik.org>

J. Math. Comput. Sci. 11 (2021), No. 1, 265-277

<https://doi.org/10.28919/jmcs/5160>

ISSN: 1927-5307

## **SYSTEMATIC ANALYSIS OF BLUE-CHIP COMPANIES OF NIFTY 50 INDEX FOR PREDICTING THE STOCK MARKET MOVEMENTS USING ANFIS MACHINE LEARNING APPROACH**

R. SHANKAR<sup>1</sup>, D. SRIDHAR<sup>2,\*</sup>, K. SIVAKUMAR<sup>3</sup>

<sup>1</sup>PSG College of Technology, Coimbatore, India

<sup>2</sup>Sri Krishna Adithya College of Arts and Science, Coimbatore, India

<sup>3</sup>Government Arts College, Coimbatore, India

Copyright © 2021 the author(s). This is an open access article distributed under the Creative Commons Attribution License, which permits unrestricted use, distribution, and reproduction in any medium, provided the original work is properly cited.

**Abstract.** Stock market plays an important role in the capital formation of a country. The stock market is often considered as the primary indicator of a country's economic condition, its strength, and development. Companies with a good performance supposedly will have a good demand on its stock, hence boost the price and vice versa. However, there's manipulation game in the market. Rumors, speculation and short-selling are among the manipulation activities that affect the fluctuation of stock price. The present study is intended to analyse the risk and return of select blue chip companies listed in NIFTY 50 Index using Adaptive neuro-fuzzy inference system, which may prove to be beneficial to the investors who makes investment.

**Keywords:** stock market; speculation; blue chip companies and risk and return; ANFIS; prediction.

**2010 AMS Subject Classification:** 03E72.

---

\*Corresponding author

E-mail address: [ursridhardeva@gmail.com](mailto:ursridhardeva@gmail.com)

Received November 2, 2020

## **1. INTRODUCTION AND PROBLEM DISCUSSION**

With the increasing global competition, companies are focusing their efforts on creating shareholder value in order to survive the intense competition. In view of this, it is becoming important for companies to measure the value they create for their shareholders. Keeping track of the value created year-on-year enables companies to evaluate past decisions and make decisions that will improve shareholder value. Investors and market analysts resort to financial statement analysis when it comes to share investing. The information on Earnings per Share (EPS) is presented on the Income Statement while Return on Assets (ROA), which is one of the profitability ratios, is computed using relevant numbers from the Income Statement and Balance Sheet. The broad area of financial accounting and reporting offers a number of fundamental measures of a firm's performance for a particular accounting period.

Financial performance announcement is the process of producing statements that disclose an organization's financial status to the internal and external users of the information. The four basic reports are balance sheets, income statements, cash flow statements and statements of shareholders' equity. Financial reports are often prepared to cover a specific financial period. While some cover an entire year, other reports only cover a specific period, such as a quarterly report. Financial statements act as tools of communication on a firm's performance especially during the period under review, performance announcements provide a modest but not overwhelming amount of information to the market. Fama (1970) states that in an efficient market, the security prices are presumed to reflect the effects of information based on past, current and future events. In an efficient market, any earnings or dividend announcement contains information which influences the stock prices positively or negatively. Investors use that information to make investment decisions accordingly. However, the validity of the efficient markets hypothesis has been questioned through the emergence of behavioural finance by postulating that financial markets might fail to reflect economic fundamentals under a number of conditions which can result in significant and persistent biases. Hirshleifer (2001) explained that investors are not always rational and may not correctly process all available information while

forming their expectations of an asset's future performance and, as such, trades could occur as a result of such irrationality.

On this, the researcher has structured the following research objective:

- To analyse the risk and return of select blue chip companies listed in NIFTY 50 Index.

## **2. MODERN APPROACH TO STOCK MARKET ANALYSIS**

### **Qualitative Analysis**

News feeds regarding stock market highly affect the market trend and thus form a downhill movement in case of negative news. Thus, the media/social network and stock market data are highly coupled and make the system more unpredictable. Existing research points out that in case of crisis, stocks mimic each other and lead to market crashes (Hellstrom 1998). Nowadays, Twitter has come forth as the most reliable and fastest way of consuming media. With combined resources of news feed and Twitter feed, general population sentiment about a company can be highlighted. Text mining and sentiment analysis are useful tools for such a high-scale analysis.

### **Quantitative Analysis**

Historical data is now readily available for most markets. Using this dataset, we can apply multiple machine learning models to give accurate results for future investments. These models can be trained for individual stocks with adjusted bias for most reflective features. These models can also be trained to work in different scenarios and overall market movement Traditional approach focuses on fundamental analysis and technical analysis to predict the market at a large scale which rarely translates to low-level individual Stock Prediction, but it can be clearly observed that individual stocks contribute to whole market movement rather than the other way around. Thus, focusing on individual stocks to predict market movement is a much more logical approach. With technology advancing at such a rapid pace and abundance of computing power, we can now easily strive towards a comprehensive system to accurately predict the market trend and reap beneficial financial returns. Existing research proves that modern approach outperforms traditional approach and can output the most accurate results (Hellstrom 1998).

### **3. METHODOLOGY OF THE STUDY**

Research has been conducted using data that are mostly secondary in nature and they are collected from CMIE (Centre for Monitoring Indian Economy) PROWESS database. The share prices of NSE were collected for the companies from 1st April 2009 to 31st March 2019. Along with share prices, intra-day open, close, adjusted closing price, volume, Net profit were collected from different sources such as capitaline.com, yahoo.com (finance), and moneycontrol.com. The study covers a period of ten years from 1<sup>st</sup> April, 2009 to 31<sup>st</sup> March, 2019. The following companies are being chosen based on the market capitalization; Bharti Airtel, Tata Consultancy Services Ltd.(L), Reliance Industries Ltd.(L), HDFC Bank Ltd.(L), Hindustan Unilever Ltd.(L), Housing Development Finance Corporation Ltd.(L), Infosys Ltd.(L), ITC Ltd.(L), Kotak Mahindra Bank Ltd.(L), State Bank Of India (L) and ICICI Bank Ltd.(L). The predictive modelling results are analysing with Adaptive Neuro-Fuzzy Inference System technique in machine learning.

### **4. STOCK MARKET PREDICTION TECHNIQUES**

The stock market prediction techniques are broadly categorized into two types, namely prediction based techniques and clustering based techniques. The techniques based on ANN, Convolutional Neural Network (CNN), Recurrent Neural Network (RNN), Decision Support System (DSS), Hidden Markov Model (HMM), Naive Bayes (NB), NN, Support Vector Regression (SVR) and SVM are grouped under prediction based techniques. Likewise, the techniques based on filtering, fuzzy, k-means, and optimization are grouped under clustering based techniques (Dattatray 2019)

#### **Performance Criteria**

To compare the classification models and evaluate their performance, three different performance criteria are used: accuracy, sensitivity, and specificity. Computation of these performance metrics are adopted as follows:

$$Accuracy = \frac{TP+TN}{TP+TN+FP+FN}$$

$$Sensitivity = \frac{TP}{TP+FN}$$

$$Specificity = \frac{TN}{TN+FP}$$

where TP, TN, FP, FN denote true positive, true negative, false positive and false negative respectively and are defined as:

True positive: number of samples classified as true while they actually were true

False positive: number of samples classified as true while they actually were false

False negative: number of samples classified as false while they actually were true

True negative: number of samples classified as false while they were actually false

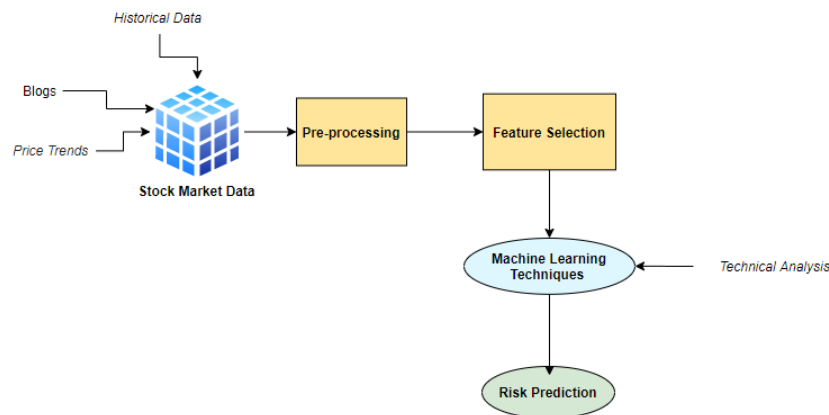

**Fig. 1. Stock market prediction using Machine Learning Algorithm**

Accuracy is a practical performance criterion that shows the directional success of the proposed model. It is the ratio of the correct predictions of upward and downward movements. Sensitivity and specificity, measure the model's ability to recognize the positive and negative values of any nodes. A confusion matrix is a summary of the classification model results displayed in a matrix representation. The rows represent the actual classes and the columns represent the predicted classes. For example, a two-class prediction classification problem display results are illustrated as in Table

		Predicted Class	
		Positive	Negative
Actual Class	Positive	True Positive (TP)	False Positive (FP)
	Negative	False Negative (FN)	True Negative (TN)

Table 1: Confusion matrix for the current two-class classification problem

Since accuracy of this current data analytic methodology depends on the correct predictions of all movements of the index (up or down), it is an important metric as buy/sell decisions are based on predictions that the index would rise or fall. A simple trading strategy is proposed here to act on the forecasts: No Threshold All In/Out. All trades are conducted at the start of the trading day at the opening value of BIST 100. The models predict the closing value at the end of the trading day. If the market is predicted to rise by any amount without any threshold, this signals a ‘buy’. On the other hand, if it is predicted to fall, this signals a “sell”. On the first day that a buy signal is received from the model, an investment is made in the BIST 100 fund using the full capital amount. Buy signals on subsequent days are treated as hold instructions until a sell signal is received. All investment units currently held are sold at the current price after a sell signal, and the capital is converted back to cash. Subsequent days’ sell signals are again treated as non-trade instructions, until another buy signal is received, and the process is repeated.

## 5. ADAPTIVE NEURO-FUZZY INFERENCE SYSTEMS FOR FORECASTING

Adaptive neuro-fuzzy inference system is systematic estimation model not only among neuro-fuzzy systems but also various other machine learning techniques. The Adaptive Neuro-Fuzzy Inference System technique was originally presented by Jang (1993). ANFIS is a simple data learning technique that uses Fuzzy Logic to transform given inputs into a desired output through highly interconnected Neural Network processing elements and information connections, which are weighted to map the numerical inputs into an output.

ANFIS combines the benefits of the two machine learning techniques (Fuzzy Logic and Neural Network) into a single technique, Jang (1993). An ANFIS works by applying Neural Network

learning methods to tune the parameters of a Fuzzy Inference System (FIS). There are several features that enable ANFIS to achieve great success Jang (1995, 1997):

- It refines fuzzy IF-THEN rules to describe the behavior of a complex system;
- It does not require prior human expertise;
- It is easy to implement;
- It enables fast and accurate learning;
- It offers desired data set; greater choice of membership functions to use; strong generalization abilities; excellent explanation facilities through fuzzy rules; and
- It is easy to incorporate both linguistic and numeric knowledge for problem solving.

Different rules cannot share the same output membership function. The number of membership functions must be equal to the number of rules. To present the ANFIS architecture, two fuzzy IF-THEN rules based on a first order Sugeno model are considered:

Rule<sub>(1)</sub>: **IF**  $x$  is  $A_1$  **AND**  $y$  is  $B_1$ , **THEN**

$$f_1 = p_1x + q_1y + r_1.$$

Rule<sub>(2)</sub>: **IF**  $x$  is  $A_2$  **AND**  $y$  is  $B_2$ , **THEN**

$$f_2 = p_2x + q_2y + r_2.$$

where:

- $x$  and  $y$  are the inputs,
- $A_i$  and  $B_i$  are the fuzzy sets,
- $f_i$  are the outputs within the fuzzy region specified by the fuzzy rule, and
- $p_i$ ,  $q_i$ , and  $r_i$  are the design parameters that are determined during the training process.

Fig. 2 illustrates the reasoning mechanism for this Sugeno model, which is the basis of the ANFIS model.

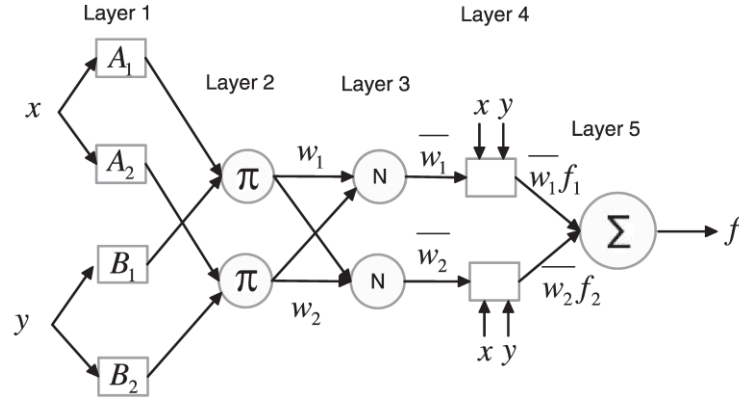

**Fig. 2. ANFIS architecture**

The ANFIS architecture used to implement these two rules is shown in Fig. 4. In this figure, a circle indicates a fixed node, whereas a square indicates an adaptive node. ANFIS has a five-layer architecture. Each layer is explained in detail below.

In  $\{\text{Layer}\}_{(1)}$ , all the nodes are adaptive nodes. The outputs of  $\{\text{Layer}\}_{(1)}$  are the fuzzy membership grade of the inputs, which are given by the following equations:

$$O_{1,i} = \mu A_i(x), i = 1,2,$$

$$O_{1,i} = \mu B_i - 2(y), i = 3,4, \quad (2)$$

where  $x$  and  $y$  are the inputs to node  $i$ , and  $A_i$  and  $B_i$  are the linguistic labels (high, low, etc.) associated with this node function.  $\mu_{A_i}(x)$  and  $\mu_{B_i-2}(y)$  can adopt any fuzzy membership function. For example, if the bell-shaped membership function

$$\mu A_i(x) = \frac{1}{1 + \left[ \left( \frac{x-c_i}{a_i} \right)^2 \right] b_i}, i = 1,2, \quad (3)$$

is employed,  $\mu A_i(x)$  is given by

or the Gaussian membership function by

$$\mu A_i(x) = \exp \left[ - \left( \frac{x-c_i}{a_i} \right)^2 \right], \quad (4)$$

where  $a_i$ ,  $b_i$ , and  $c_i$  are the parameters of the membership function.

In  $\{\text{Layer}\}_{(2)}$ , the nodes are fixed nodes. This layer involves fuzzy operators; it uses the AND operator to fuzzify the inputs. They are labeled with  $\pi$ , indicating that they perform as a simple multiplier. The output of this layer can be represented as

$$O_{2,i} = \omega_i = \mu A_i(x) * \mu B_i(y), i = 1,2. \quad (5)$$



These are the so-called firing strengths of the rules. In  $\{\text{Layer}_{(3)}\}$ , the nodes are also fixed nodes labeled by  $N$ , to indicate that they play a normalization role to the firing strengths from the previous layer. The output of this layer can be represented as

$$O_{3,i} = \bar{\omega}_i = \frac{\omega_i}{\omega_1 + \omega_2}, \quad i = 1, 2. \tag{6}$$

Outputs of this layer are called normalized firing strengths.

In  $\{\text{Layer}_{(4)}\}$ , the nodes are adaptive. The output of each node in this layer is simply the product of the normalized firing strength and a first order polynomial (for a first order Sugeno model). The output of this layer is given by

$$O_{4,i} = \bar{\omega}_i f_i = \bar{\omega}_i (p_i x + q_i y + r_i), \quad i = 1, 2. \tag{7}$$

where  $\bar{\omega}$  is the output of  $\{\text{Layer}_{(3)}\}$ , and  $p_i$ ,  $q_i$ , and  $r_i$  are the consequent parameters. In  $\{\text{Layer}_{(5)}\}$ , there is only one single fixed node labeled with  $\sum$ . This node performs the summation of all incoming signals. The overall output of the model is given by

$$O_{4,i} = \sum_i \bar{\omega}_i f_i = \frac{\sum_i \omega_i f_i}{\sum_i \omega_i} \tag{8}$$

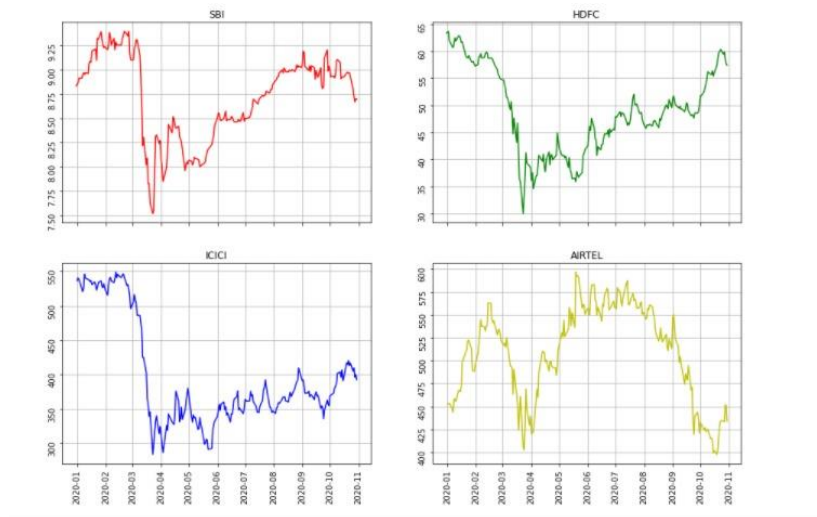

**Fig. 3. Stock market prediction**

**6.ANALYSIS AND DISCUSSION****Table 2: Risk and Return of select blue chip companies listed in NIFTY 50 Index**

Sr. No	Security Name	Mean Return% ( $R_i$ )	Variance Security $\sigma_i^2$	Beta ( $\beta_i$ )	$R_f$	Variance Market ( $\sigma^2$ ) M	Excess Return % ( $R_i - R_f$ )	Excess Return To
								Beta ( $R_i - R_f$ ) $\beta_i$
1.	Bharti Airtel	16.70	9.78	0.68	5.98	16.98	10.72	15.76
2.	HDFC Bank Ltd.	35.78	12.33	0.79	5.98	16.98	29.80	37.50
3.	HDFC Ltd.	29.22	13.82	0.88	5.98	16.98	23.24	26.27
4.	Hindustan Unilever Ltd.	51.41	99.07	2.11	5.98	16.98	45.43	21.55
5.	I T C Ltd.	35.19	1.95	0.30	5.98	16.98	29.21	97.02
6.	ICICI Bank Ltd.	26.25	34.37	1.36	5.98	16.98	20.27	14.87
7.	Infosys Ltd.	20.07	50.76	1.49	5.98	16.98	14.09	9.49
8.	Kotak Mahindra Bank Ltd.	38.09	33.73	1.34	5.98	16.98	32.11	23.94
9.	Reliance Industries Ltd.	8.03	22.16	1.13	5.98	16.98	2.05	1.82
10.	State Bank of India	16.64	25.49	1.18	5.98	16.98	10.66	9.04

Source: Computed Data

It is found from Table 2.that stocks like Reliance Industries have negative returns. The negative returns may be due to macroeconomic events taking place in the economy. Most of the companies listed in Index have Beta either equal to or more than 1. Banks like ICICI and SBI have Beta more than 1. Hindustan Unilever Limited has the highest beta of 2.11. Though these stocks with beta greater than 1 are aggressive securities but stock of Hindustan Unilever Limited is most volatile of all the stocks. The returns of these companies are more volatile to changes in the market. Some securities like Bharti Airtel (0.68), HDFC Bank (0.79), HDFC Ltd (0.88) and ITC Ltd (0.30) have beta less than 1. It can be seen that majority of securities have beta more than 1.The movement of such securities is high than market movement, hence called aggressive securities. The investors who are willing to take risk invest in such securities because of higher the risk and higher the returns.

## **7. CONCLUSION**

Stock market prediction is the act of trying to determine the future value of a company stock or other financial instrument traded on an exchange. The successful prediction of a stock's future price could yield significant profit. The efficient-market hypothesis suggests that stock prices reflect all currently available information and any price changes that are not based on newly revealed information thus are inherently unpredictable. Investment plan has a greater chance of success if the investor follows a disciplined approach to each of these factors. The investor's interest is better served by choosing investment products that are different from each other, but where each of them is doing its best to control these factors in its own steady way. In this study, the application of ANFIS machine learning approach was evaluated for Stock market prediction. Several influencing parameters such as adjusted closing price, volume and Net profit have been considered in the ANFIS mode and the results suggest that the ANFIS method can be successfully applied to predict the Stock market movements.

## **CONFLICT OF INTERESTS**

The authors declare that there is no conflict of interests.

**REFERENCES**

- [1] P.N. Afego, Stock Price Response to Earnings Announcements: Evidence From the Nigerian Stock Market, *J. Afr. Bus.* 14 (2013), 141–149.
- [2] M. Aga, B. Kocaman, Efficient market hypothesis and emerging capital markets: empirical evidence from Istanbul stock exchange. *Int. Res. J. Finance Econ.* 73(1) (2008), 131-144.
- [3] J.D. Arthurs, L.W. Busenitz, R.A. Johnson, R.E. Hoskisson, Signaling and initial public offerings: The use and impact of the lockup period. *J. Bus. Ventur.* 24 (2009), 360-372.
- [4] R. Ball, S. Kothari, Security returns around earnings announcements. *Account. Rev.* 66(4) (1991), 718-738.
- [5] R. Ball, P. Brown, An Empirical Evaluation of Accounting Income Numbers, *J. Account. Res.* 6 (1968), 159-178.
- [6] S. Brown, J. Warner, Using daily stock returns; The Case of Event Studies. *J. Financ. Econ.* 14 (1985), 3-31.
- [7] C. Chemarum, Market Reaction to Stock splits: Empirical evidence from the Nairobi Stock Exchange. *Afr. J. Bus. Manage.* 1 (2010), 165-184.
- [8] R.A.K. Cox, T.R. Weirich, The stock market reaction to fraudulent financial reporting. *Manage. Audit. J.* 17(7) (2002), 374-382.
- [9] M.K. Dey, B. Radhakrishna, Who profits from trading around earnings announcements? Evidence from TORQ data. *J. Asset Manage.* 9(4) (2008), 300- 308.
- [10] A. Eilifsen, K. Knivsfla, F. Sættem, Earnings Manipulation: Cost of Capital Versus Tax. *Eur. Account. Rev.* 8(3) (1999), 481-91.
- [11] C.S. Eun, G.B. Resnick, S. Sabherwal, *International Finance*. (Sixth ed.), McGraw-Hill, New York. (2012).
- [12] E. Fama, L. Fisher, M. Jensen, R. Roll, The Adjustment of Stock Prices to New Information, *Int. Econ. Rev.* 10 (1969), 1-21.
- [13] E.F. Fama, Efficient Capital Markets: A Review of Theory and Empirical Work, *J. Finance* 25 (1970), 383-417.
- [14] G. Foster, C. Olsen, T. Shevlin, Earnings Releases Anomalies and Behavior of Security Prices, *Account. Rev.* 1 (1984), 574-603.
- [15] A. Gupta, Impact of Earnings Announcements on Stock Prices: Some Empirical Evidences from India, *ICFAI J. Appl. Finance*, 12(3) (2006), 5-16.

## SYSTEMATIC ANALYSIS OF BLUE-CHIP COMPANIES

- [16] D. Hirshleifer, *Investor Psychology and Asset Pricing*. *J. Finance*, 56 (2001), 1533-1597.
- [17] I. Javid, A.F. Faraz, *The Stock Price Reaction to Earnings Announcement: The case of an Emerging Market*. Department of Statistics, Karachi University, Pakistan, Retrieved October 7, 2011, <http://mpa.ub.unimuenchen.de/30865>. (2011).
- [18] M. Kiremu, *Stock Price and Volumes Reaction to Annual Earnings Announcement: A Case of the Nairobi Securities Exchange*, *Int. J. Bus. Human. Technol.* 3 (2013), 101-111.
- [19] L. Laidroo, *Public announcement induced market reactions on Baltic stock exchanges*. *Baltic J. Manage.* 3(2) (2008), 174-192.
- [20] K. Lyroudi, A. Dasilas, A. Varnas, *The valuation effects of stock splits in NASDAQ*. *Manage. Finance*, 32(5) (2006), 401-414.
- [21] M. Mabhunu, *The market efficiency hypothesis and the behaviour of stock returns on the JSE securities exchange*. Doctoral dissertation, Rhodes University. (2004).
- [22] J.-S.R. Jang, *ANFIS: adaptive-network-based fuzzy inference system*, *IEEE Trans. Syst., Man, Cybern.* 23 (1993), 665–685.
- [23] J.-S.R. Jang, Chuen-Tsai Sun, *Neuro-fuzzy modeling and control*, *Proc. IEEE*. 83 (1995) 378–406.
- [24] J.S.R. Jang, C.T. Sun, E. Mizutani, *Neuro-Fuzzy and Soft Computing*. Prentice Hall, 1997.
- [25] D.P. Gandhmal, K. Kumar, *Systematic analysis and review of stock market prediction techniques*, *Computer Sci. Rev.* 34 (2019), 100190.
- [26] T. Hellstrom, K. Holmstrom, *Predicting the Stock Market*. Technical Report Series IMA-TOM-1997-07 (1998).